

# GAUGE PRESSURE REGULATOR

RM

<b>Description</b>	Diaphragm-operated pressure regulator with integrated gauge in the handwheel. The regulator is user-friendly and saves on space for a gauge in panel.		
<b>Adjustment</b>	Knob with integrated gauge. The RM1 regulator has a tamper-proof knob with snap-lock.		
<b>Relieving function</b>	relieving as standard		
<b>Supply pressure</b>	RM1: max. 16 bar	RM2: max. 25 bar	
<b>Pressure gauge</b>	RM1: scale in bar	RM2: scale in bar and psi readable down to 3 bar for 10/16 bar range	
<b>Temperature range</b>	RM1: -10 °C to 60 °C / 14 °F to 140 °F	RM2: -10 °C to 90 °C / 14 °F to 190 °F	
<b>Material</b>	RM1: body: zinc die-cast elastomer: NBR/Buna-N	RM2: body: zinc die-cast and aluminium elastomer: NBR/Buna-N	

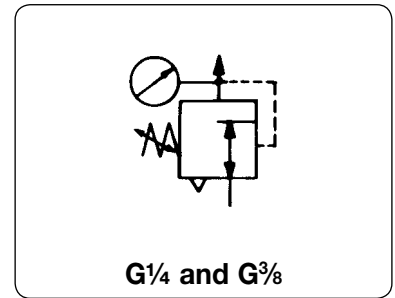

Standard  
2

Dimensions			K <sub>v</sub> -value (m <sup>3</sup> /h)	Flow rate		Connection thread G	Pressure range bar	Order number
A	B	C		m <sup>3</sup> /h*1	l/min*1			

Pressure regulator, P <sub>1</sub> max. 16 bar							including nut, gauge range approx. 30% above pressure range	RM1
48	136	26	1.2	84	1400	G <sup>1</sup> / <sub>4</sub>	0.1... 3	RM1-02A
							0.2... 6	RM1-02B
							0.3...10	RM1-02C
48	136	26	1.3	90	1500	G <sup>3</sup> / <sub>8</sub>	0.1... 3	RM1-03A
							0.2... 6	RM1-03B
							0.3...10	RM1-03C



Pressure regulator, P <sub>1</sub> max. 25 bar							including nut, gauge range approx. 30% above pressure range	RM2
54	145	30	0.9	66	1100	G <sup>1</sup> / <sub>4</sub>	0.1... 3	RM2-02A
							0.2... 6	RM2-02B
							0.3...10	RM2-02C
							0.5...16	RM2-02D
54	145	30	1.0	72	1200	G <sup>3</sup> / <sub>8</sub>	0.1... 3	RM2-03A
							0.2... 6	RM2-03B
							0.3...10	RM2-03C
							0.5...16	RM2-03D

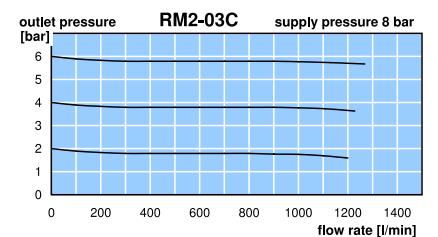
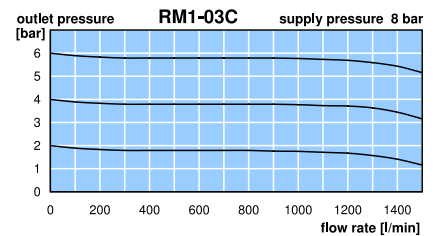
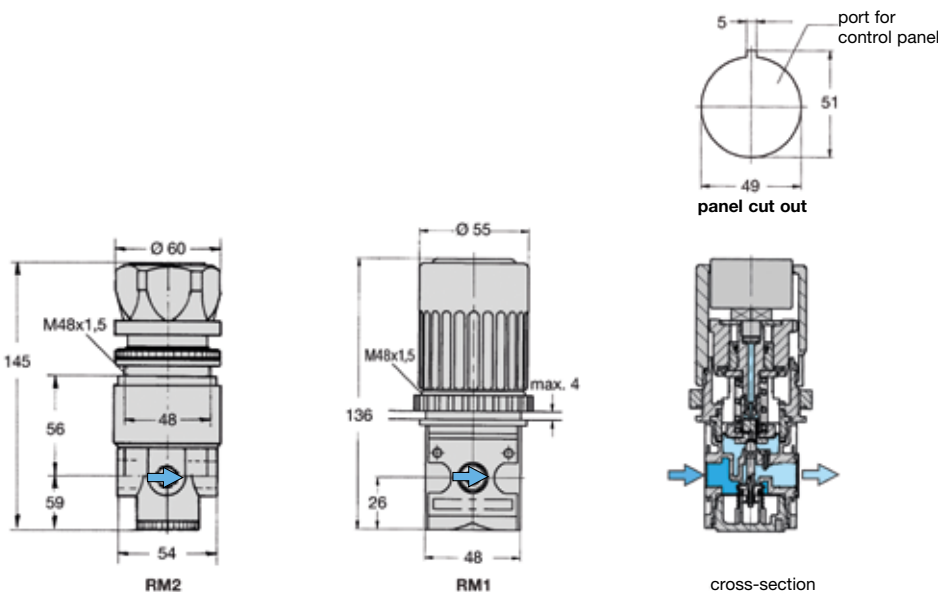

\*1 at 7 bar supply pressure, 6 bar outlet pressure and 1 bar pressure drop